

UNCONTROLLED
For Reference Only
MB 10/20/2009

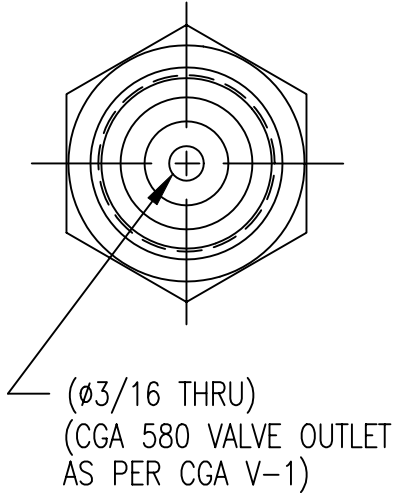
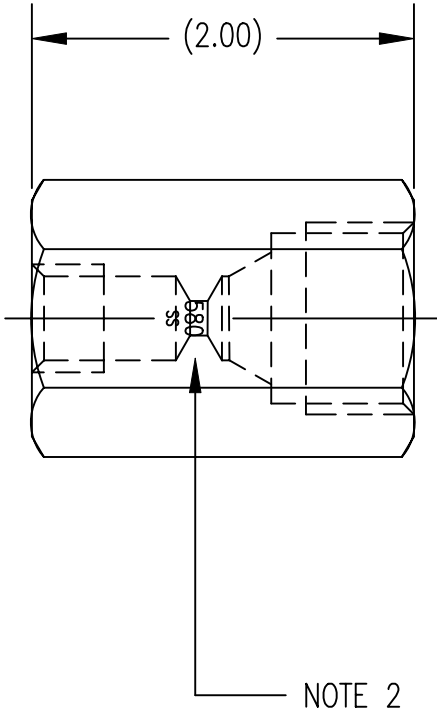
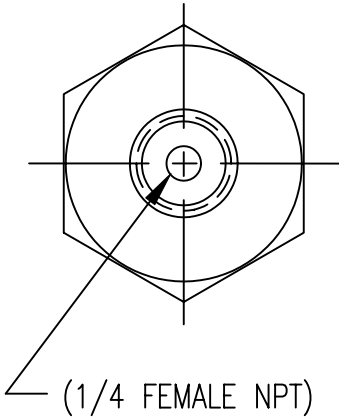

- NOTES:
1. DIMENSIONS ARE IN INCHES.
 2. MARK AS SHOWN: 2 MM HIGH "580"
1 1/2 MM HIGH "SS"
MARKING MUST BE PERMANENT.
 3. CLEANED & PACKAGED FOR OXYGEN SERVICE.

GasFlo Products Inc.
Fairfield, N.J.
SALES DRAWING- VALVE OUTLET ADAPTER
CGA 580 x 1/4" FNPT
DWG SALES-AD-580FSS-4FNPT

THIS DOCUMENT CONTAINS INFORMATION THAT IS THE PROPRIETARY AND CONFIDENTIAL PROPERTY OF GASFLO PRODUCTS INC. AND MAY BE USED ONLY FOR AUTHORIZED PURPOSES. THIS DOCUMENT MAY NOT BE REPRODUCED WITHOUT GASFLO PRODUCTS INC. PRIOR WRITTEN CONSENT.

MAT'L	1 1/4 HEX 316L SST
DWN	MB
APPVD	
SCALE:	NTS
DATE	4/18/05