

#PA	D5FHB5A 9	A 5H9F-5@	E HM
%	B-DD@	' %* @GGH	%
&	BI H	' \$' GGH	%
'	585DHC F	' %* @GGH	%

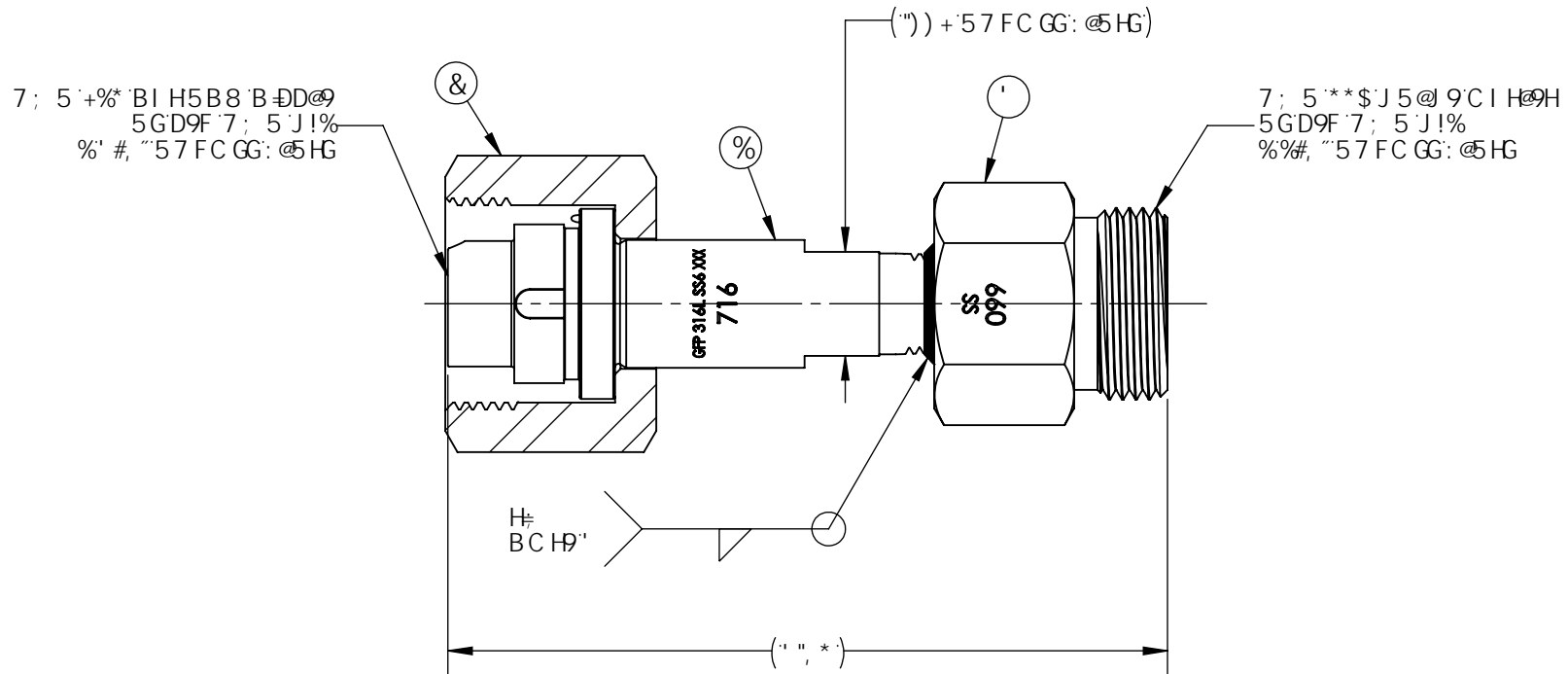

G5@9G'8F 5K -B;
I B7CBHFC @Q8
: CF
F9: 9F9B79
CB@M

BC H9G
 % 8-A 9BG C BG5F9 B B7 <9G'
 & C I H C 5F8 @95? H9G 98 K Hk % \$ \$ DG# <9@# A "
 ' " G-B; @DC @M65; ; 98" 65; @5 69@98 K Hk; ; D'@C; C Z
 D5FHBI A 69F Z' I @F 5GC B 7 5 @M8 " " 7 @95B 98 Z5B8'
 "A 589 B Hk 91 "G5"

UOX	OWUOPVAJOXQIQP	ÖEVO
5	ÖÜVÖŠPÄÖÜÖÜCY @ÖÄUÄPÖÄVÖT	FCBE EDEFI

OOUOUQVQPK		
OEOEUUVUÜÄÖÖZÄ FÎ ÄZÖT OESÖÄÄÖÖZÄ Î €Ä T OESÖÄJU		
UOEUVÄPWT ÖOUK		
58!+% : ** \$A!GG		
UZOIA CE	UOCESOA PVU	T OEVGK G99 '6 'C'A "
UPOOVA/PWT ÖOUK FAJÖAF	ÖÜCY PÄÖYKÖT ~ * æ^! [Ä } ÄFCBE EDEFI	

GFP
 ; 5G: @C DFC8I 7HG
 : UfZYXZB>\$+\$\$(
 ÖEUÜK { ä [t&a Ä } ÄFCBE EDEFI