

| ITEM | PART NAME | MATERIAL | QTY. |
|------|------------|--------------------------|------|
| 1 | PLUG | BRASS CDA-360 | 1 |
| 2 | CAP NUT | BRASS CDA-360 | 1 |
| 3 | STEM | BRASS CDA-360 | 1 |
| 4 | CLIP RING | BRASS PLATED SPRING WIRE | 1 |
| 5 | CHAIN | BRASS PLATED STEEL | 1 |
| 6 | LATCH RING | CHROME PLATED STEEL | 1 |

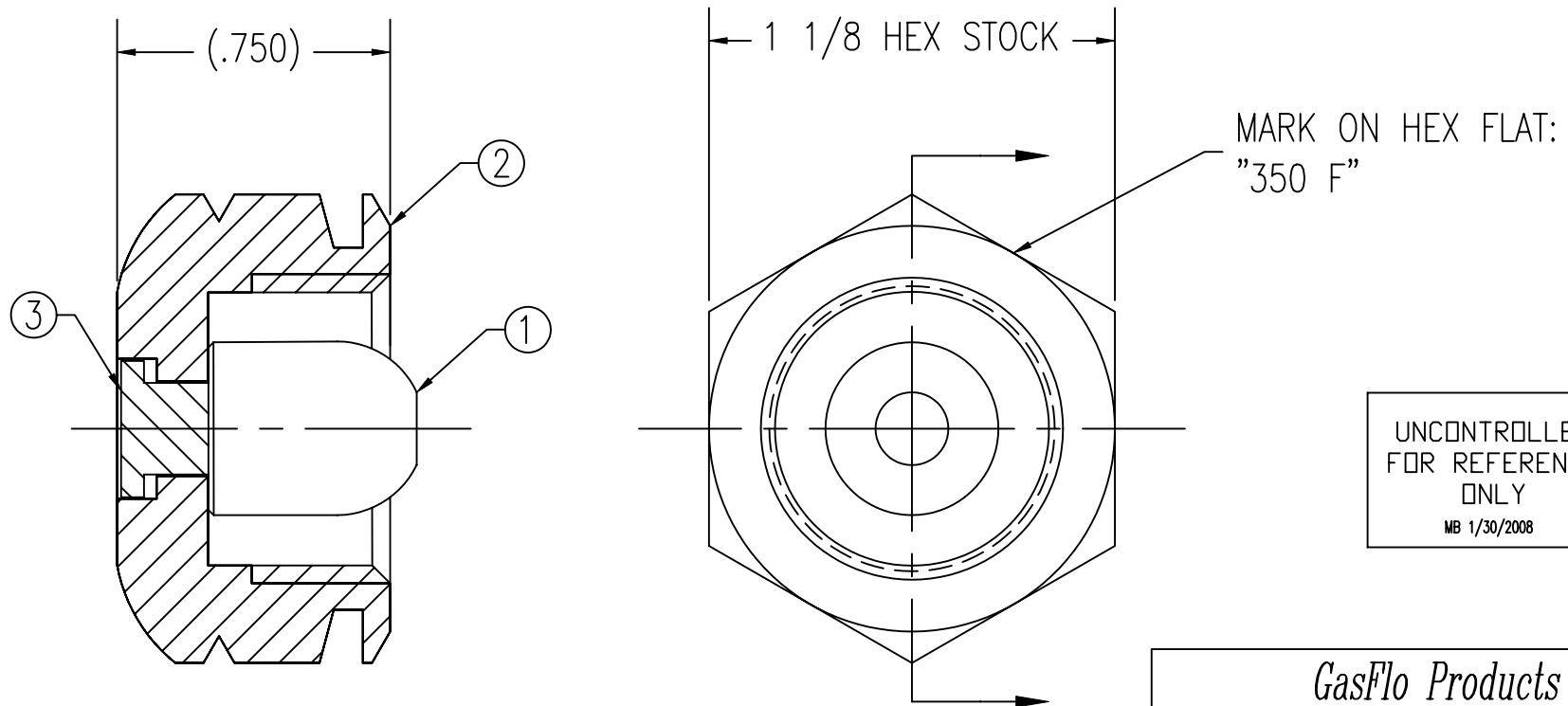

NOTES:

1. DIMENSIONS ARE IN INCHES.
2. CLIP RING, CHAIN, AND LATCH RING ARE OMITTED FOR CLARITY.

THIS DOCUMENT CONTAINS INFORMATION THAT IS THE PROPRIETARY AND CONFIDENTIAL PROPERTY OF GASFLO PRODUCTS INC. AND MAY BE USED ONLY FOR AUTHORIZED PURPOSES. THIS DOCUMENT MAY NOT BE REPRODUCED WITHOUT GASFLO PRODUCTS INC. PRIOR WRITTEN CONSENT.

DWN MB
APPVD

SCALE: NTS
DATE 4/22/03

DWG SALES-CAP-GT350BR-R

GasFlo Products Inc.
Fairfield, N.J.

SALES DRAWING- CGA 350
GAS TIGHT OUTLET SEAL CAP