



GasFlo Products CV-SB Series Check Valves provide easy in-line installation to prevent the reverse flow of gas/fluids in analytical and high-purity assemblies. A two-piece split body poppet and spring design with an O-ring at the valve seat ensures positive shut off and quick acting response.

FEATURES

- IN-LINE SPLIT BODY CONSTRUCTION
- NEAR ZERO CLEARANCE REQUIRED FOR IN-LINE ASSEMBLY
- POPPET, SPRING AND O-RING DESIGN
- STANDARD CRACKING PRESSURE: 1/3 PSIG
- DIRECTION OF FLOW CLEARLY LASER MARKED
- ULTRASONICALLY DI CLEANED
- 100% LEAK TESTED
- CUSTOM MATERIALS AND CONFIGURATIONS AVAILABLE ON REQUEST

MATERIALS OF CONSTRUCTION

- MATERIAL OPTIONS:
 - BRASS BODY, SEAT AND POPPET WITH 316L STAINLESS STEEL SPRING
 - 316L STAINLESS STEEL BODY, SEAT, POPPET AND SPRING
- O-RING OPTIONS:
VITON® (STANDARD), EPR OR KALREZ®

MONEL® - TM - SPECIAL METALS CORPORATION

KALREZ® and VITON® - DuPONT

APPLICATIONS

- GAS PANELS
- PIGTAILS
- PURGE ASSEMBLIES
- MANIFOLD SYSTEMS

END CONNECTION OPTIONS

- 1/4" MALE FACE SEAL
- 1/4" COMPRESSION



DIMENSIONAL INFORMATION

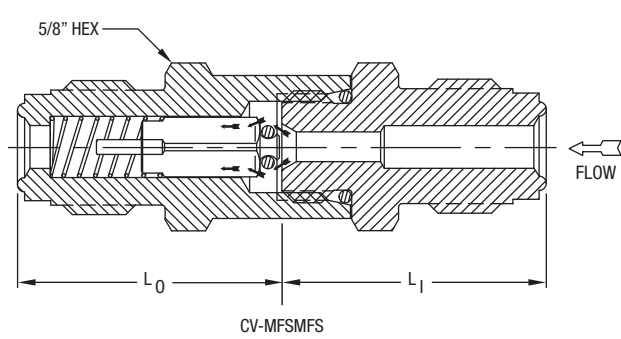
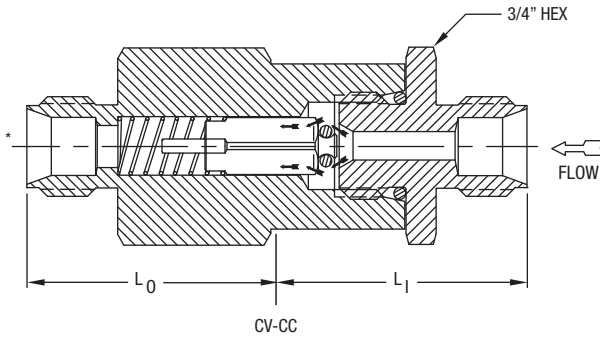

*Nuts and ferrules are deleted for clarity.

All dimensions are in inches - for reference only, subject to change.

SPECIFICATIONS

PRESSURE RATING: STAINLESS STEEL = 3000 PSIG
BRASS = 3500 PSIG
FLOW COEFFICIENT Cv = .35
SEAT ORIFICE SIZE: 0.125"

STANDARD CRACKING PRESSURE: 1/3 PSIG
STANDARD O-RING MATERIAL: VITON®
TEMPERATURE LIMITS: VITON® = -15° TO 400° F

BUBBLE TESTED AT 1000 PSIG
ULTRASONICALLY DI CLEANED

ORDERING INFORMATION

TYPICAL PART NUMBER

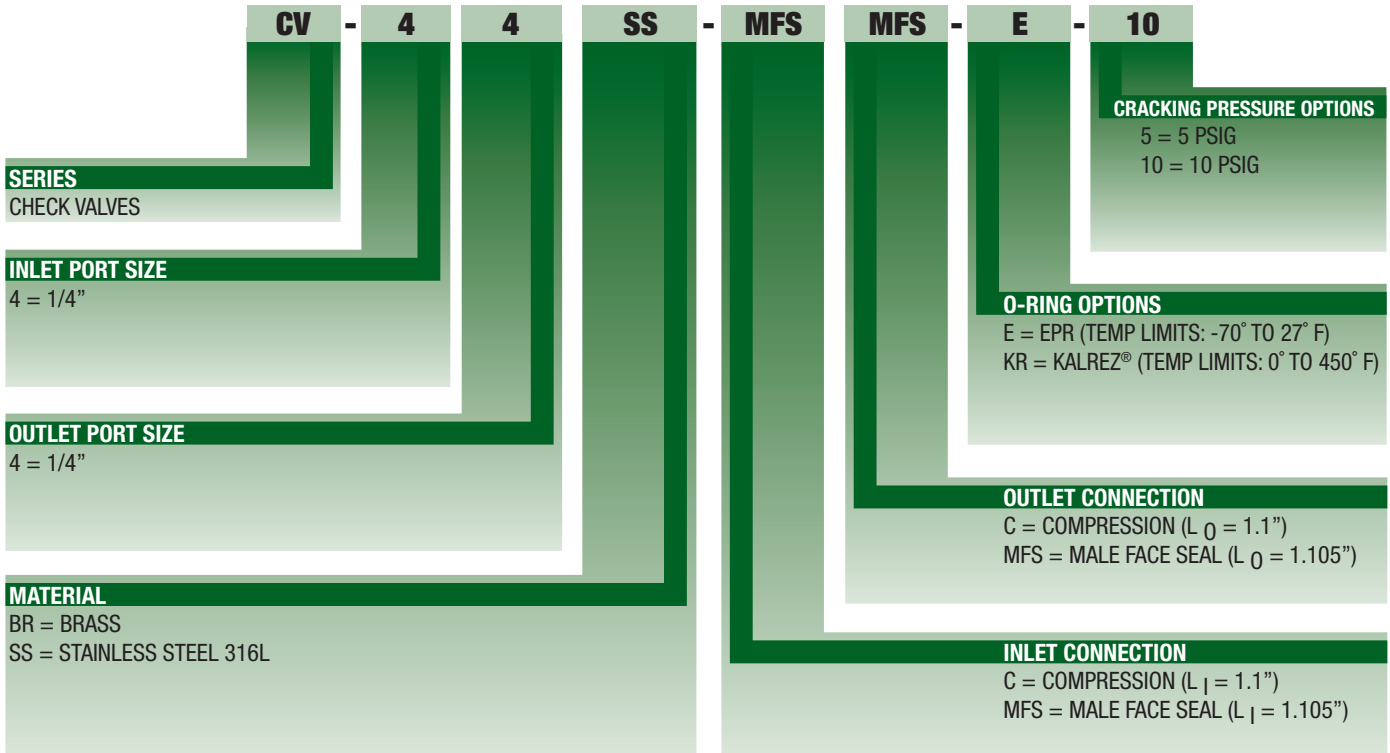

MONEL® - TM - SPECIAL METALS CORPORATION

KALREZ® and VITON® - DUPONT

1/4 NPT DESIGNS AVAILABLE, SEE CV-BS SERIES.

Minimum order quantities may be required. Some inlet/outlet combinations may not be available.

VALVE, FITTING OR OTHER COMPONENT FUNCTION, PROPER INSTALLATION, MATERIALS COMPATIBILITY, ADEQUATE RATINGS, OPERATION AND MAINTENANCE ARE THE RESPONSIBILITY OF THE SYSTEM DESIGNER AND USER.



PRODUCT FAILURE, IMPROPER SELECTION OR IMPROPER USE OF THE PRODUCTS AND/OR SYSTEMS DESCRIBED HEREIN OR RELATED ITEMS CAN CAUSE DEATH, PERSONAL INJURY AND PROPERTY DAMAGE.



19 Industrial Road, Fairfield, NJ 07004 Phone: 973-276-9011 Fax: 973-276-9014 www.gasflo.com

