

SPECIFICATIONS:

1. WORKING PRESSURE: 4000 PSI MAX.
2. CRACKING PRESSURE: 1.0 PSI

ITEM	PART NAME	MATERIAL	QTY.
1	BODY	316 SST	1
2	SPRING	316 SST	1
3	POPPET	316 SST	1
4	O-RING	VITON	1
5	WASHER	316 SST	1
6	CLIP, WIRE	316 SST	1

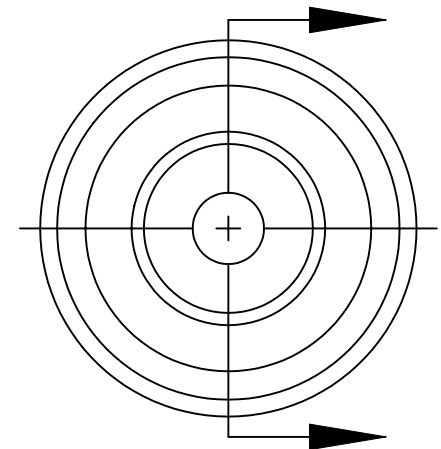
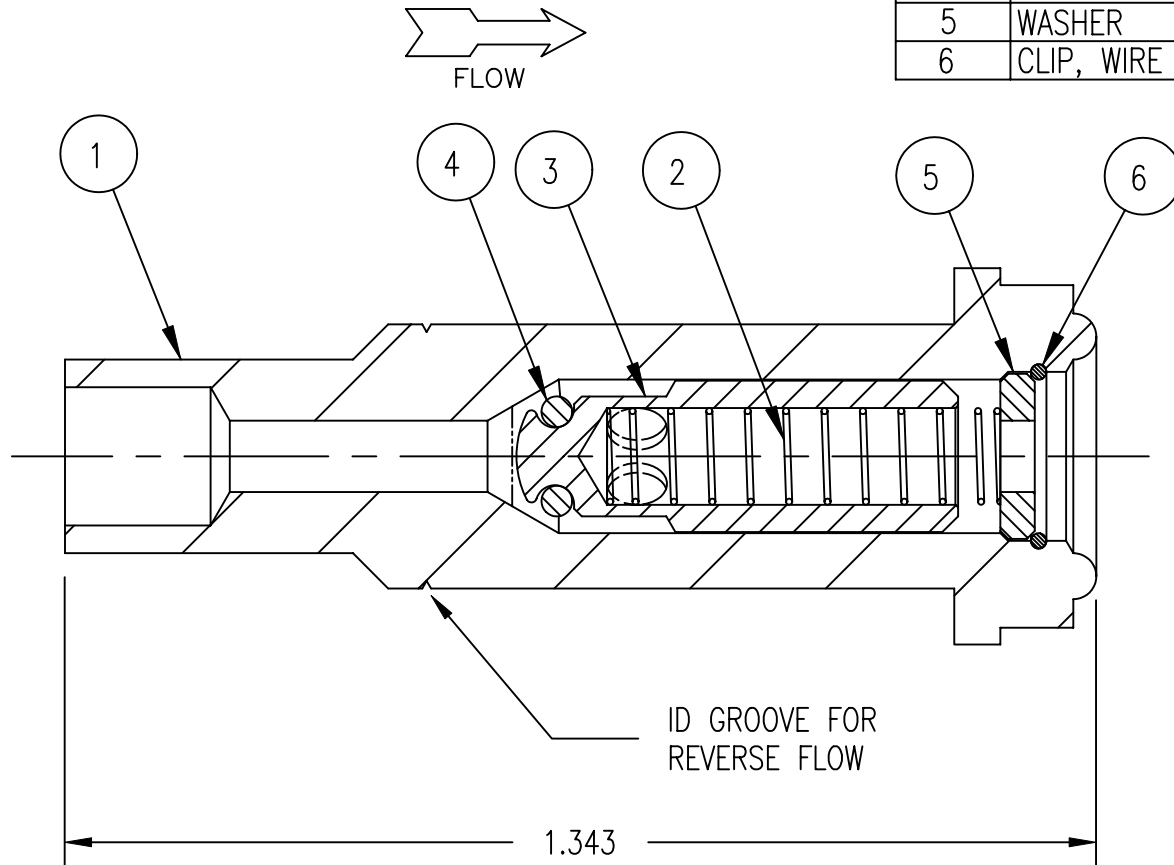

UNCONTROLLED
For Reference Only

MB 8/25/2008

NOTES:

1. DIMENSIONS ARE IN INCHES.
2. SHIP AS UNASSEMBLED COMPONENTS, BUT KITTED WITH EACH COMPONENT INDIVIDUALLY PACKAGED. LABEL PACKAGE WITH GFP LOGO, PART NUMBER, "CLEANED FOR OXYGEN SERVICE", & "MADE IN THE USA".

TOLERANCES UNLESS OTHERWISE NOTED
 FRACTIONS $\pm 1/64$ ANGLES ± 1 DEG
 .XX = ± 0.010 .XXX = ± 0.005
 CONCENTRICITY T.I.R. = $.005$
 SURFACE FINISH = $63 R_a$

MAT'L: .

DWN: FAS

SCALE: 4:1

SHT.: 1 of 1

DATE: 8/25/08

GasFlo Products Inc.
Fairfield, N.J.

FACE SEAL GLAND W/ REV. FLOW
CHECK VALVE; VITON SEAL; 316L

DWG: SALES-GLD-44SSCVTSV