

ITEM	PART NAME	MATERIAL	QTY
1	NUT	303 SST	1
2	NIPPLE	316L SST	1

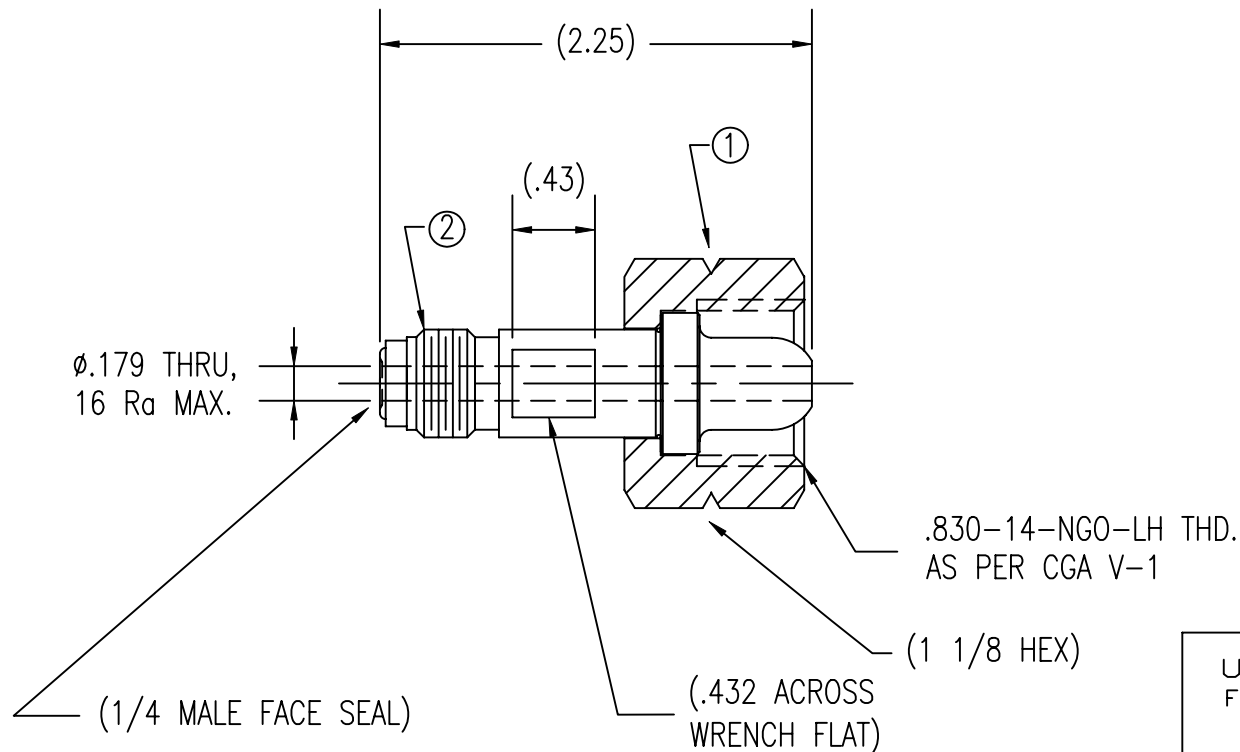

UNCONTROLLED  
For Reference Only  
MB 8/1/2011

NOTES:

1. DIMENSIONS ARE IN INCHES.
2. ORDER PART NUMBER: INL-350SS-4MFS-36.
3. NIPPLE IS ULTRASONICALLY D.I. CLEANED AND SINGLE POLY BAGGED.
4. NUT IS CLEANED FOR OXYGEN SERVICE AND SINGLE POLY BAGGED.
5. ASSEMBLY IS BULK POLY BAGGED AND LABELED WITH GFP LOGO AND GFP PART NUMBER.

*GasFlo Products Inc.*  
*Fairfield, N.J.*

SALES DRAWING- INLET CONNECTION  
CGA 350 x 1/4" MALE FACE SEAL