

ITEM	PART NAME	MATERIAL	QTY
1	NUT	303 SST	1
2	NIPPLE	316L SST	1

UNCONTROLLED
For Reference Only
MB 11/10/2011

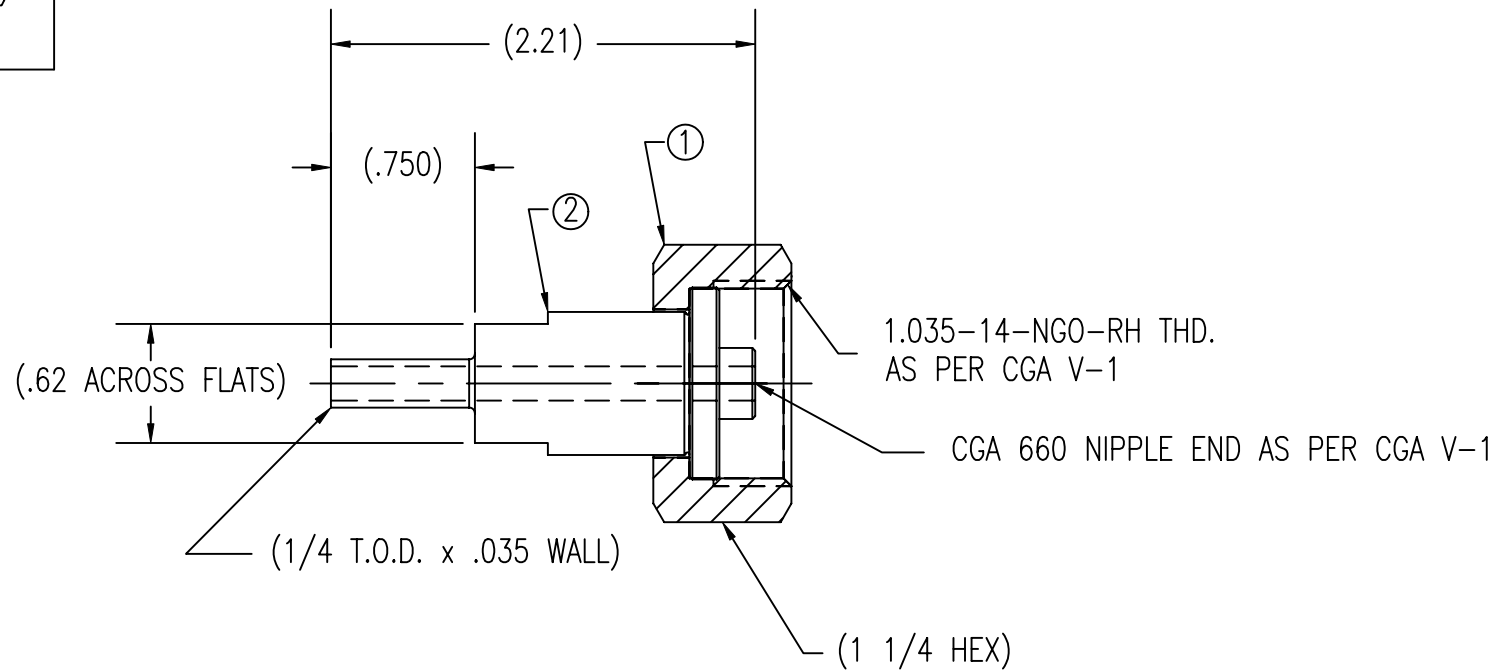

NOTES:

1. DIMENSIONS ARE IN INCHES.
2. ORDER PART NUMBER: INL-660SS-4TS-35F.
3. NIPPLE IS ULTRASONICALLY D.I. CLEANED AND SINGLE POLY BAGGED.
4. NUT IS CLEANED FOR OXYGEN SERVICE AND SINGLE POLY BAGGED.
5. ASSEMBLY IS BULK POLY BAGGED AND LABELED WITH GFP LOGO AND GFP PART NUMBER.

GasFlo Products Inc.
Fairfield, N.J.

SALES DRAWING- INLET CONNECTION
CGA 660 x 1/4" TUBE STUB