

ITEM NO.	PART NAME	MATERIAL	QTY.
1	NUT	303 SST	1
2	SEAT	316L SST	1
3	O-RING	VITON	1
4	O-RING	VITON	1
5	VALVE	316L SST	1
6	SPRING	316L SST	1
7	NIPPLE	316L SST	1
8	GASKET	PTFE	1

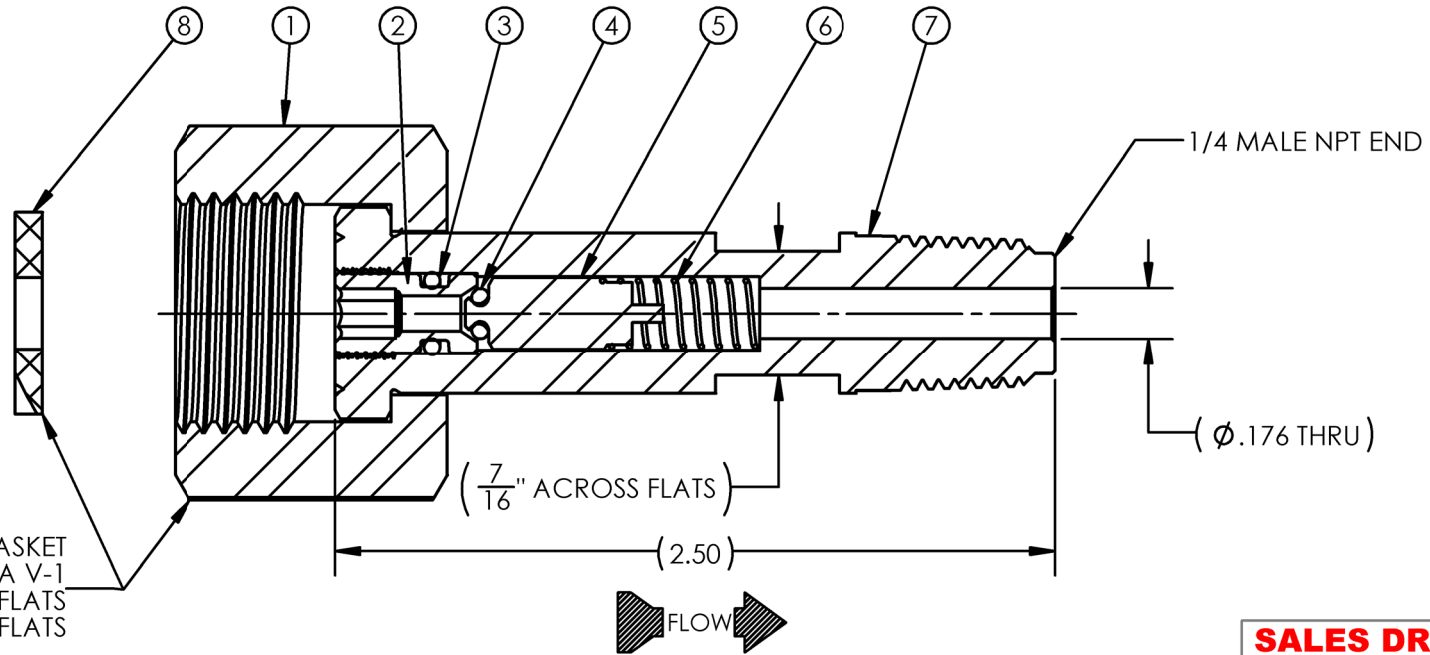

CGA 320 NIPPLE, NUT, & GASKET  
AS PER CGA V-1  
1 1/16" ACROSS NIPPLE FLATS  
1-1/8" ACROSS NUT FLATS

NOTES:

1. DIMENSIONS ARE IN INCHES.
2. MAWP: 3000 PSI
3. CRACKING PRESSURE: .25 TO 1.00 PSIG.
4. NIPPLE, NUT, AND GASKET ARE CLEANED FOR OXYGEN SERVICE AND SINGLE POLY BAGGED.
5. ASSEMBLY IS SINGLE POLY BAGGED. BAG LABELLED WITH GFP LOGO, PART NUMBER, "CLEANED FOR OXYGEN SERVICE", AND "MADE IN THE USA".

**SALES DRAWING**  
**UNCONTROLLED**  
**FOR**  
**REFERENCE**  
**ONLY**

REV	CURRENT REVISION	DATE
A	ESTABLISH GFP SALES DRAWING FOR THIS ITEM	02/24/2021

DESCRIPTION: INLET CGA 320 X 1/4 MNPT CHK-VLV SS		
PART NUMBER: INL-CV320SS-4M		



THIS DOCUMENT CONTAINS INFORMATION THAT IS THE PROPRIETARY AND CONFIDENTIAL PROPERTY OF GASFLO PRODUCTS INC. AND MAY BE USED ONLY FOR AUTHORIZED PURPOSES. THIS DOCUMENT MAY NOT BE REPRODUCED WITHOUT GASFLO PRODUCTS INC. PRIOR WRITTEN CONSENT.

SIZE: A	SCALE: NTS	MAT'L: SEE B.O.M.
SHEET NUMBER: 1 OF 1		DRAWN BY: ppanchal on 02/24/2021

APPR: mbojck on 04/01/2021