

BC H9G  
 % 8 A 9BG€ BG'5F9' B' B7 <9G"  
 & G DD@98' K #K' BI HG'5B8': 9FFI @9G' <5B8!H# <H'  
 ' " <5B8@9HC' 697 @95F'5BC8 #98"

GD97 ≈ 7 5HC BG		#9A	D5FHB5A 9	A 5HF-5@	E HM
DF9GG F9F5HB;	' ) \$\$ DG=A 5L"	%	6C 8M	' % @GGH	%
: @K '7C9: ≈ 9BH	7 j '1 ""%	&	G95H	D7 H 9	%
G95HC F ≈ 7 9GA9	Ø "%&)	'	8-5D<F5; A '5GGM"	' % @GGHK 9H98 L#7 C DD9F	%
G95HA 5HF-5@	D7 H 9	(	6C BB9H	' \$' 'GGH	%
H9A D9F5H F9@A #G	!* ) °: HC %\$°:	)	G#9A	(% 'GG	%
A 5L"5 @@K 56@G95H@95?	&L %\$!, '5HA '77 #G97 '<Y	*	DC G#C B9F'; @5B8	D@5H98 '6F5GG	%
A 5L"5-B6C 5F8 @95?	&L %\$!, '5HA '77 #G97 '<Y	+	@ 7 ?BI H	D@5H98 '6F5GG	%
K 9H98' G F: 57 9G	D7 H 9# %' @GGH	,	7 C @@F	5 @ A -BI A	%
F9D5 F ? #H	F?!G@8-5	-	GHC D'D-B	G#99@5 @@C M	%

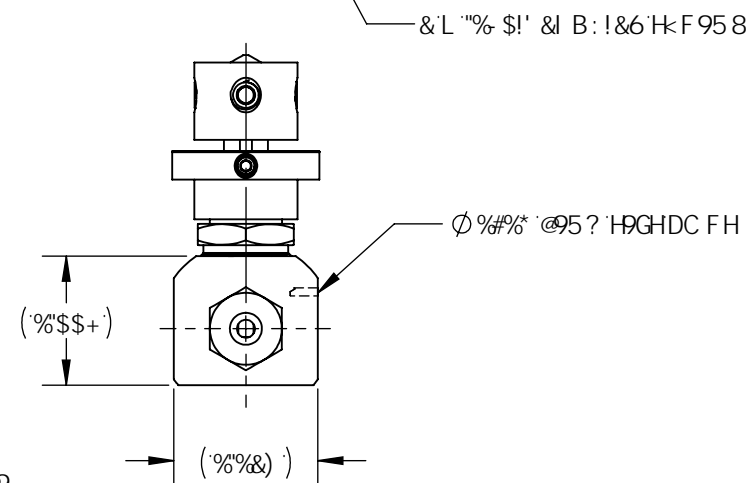

%\$	<5B8@	5 @ A -BI A	%
%8	: FC BH: 9FFI @	' % @GGH	&
%&	F95F': 9FFI @	' % @GGH	&
%	7 C A DF9GG€ B' BI H	' % @GGH	&
%{	B8-75HC F	5 @ A -BI A	%
%∅	, # & G9HG7 F9K	% !, 'GGH	%
%*	%#(' G9HG7 F9K	% !, 'GGH	'
%+	B8-75HC F @569@	J -BM@	%
%	E I 5FH9F' H FB' @569@	J -BM@	%

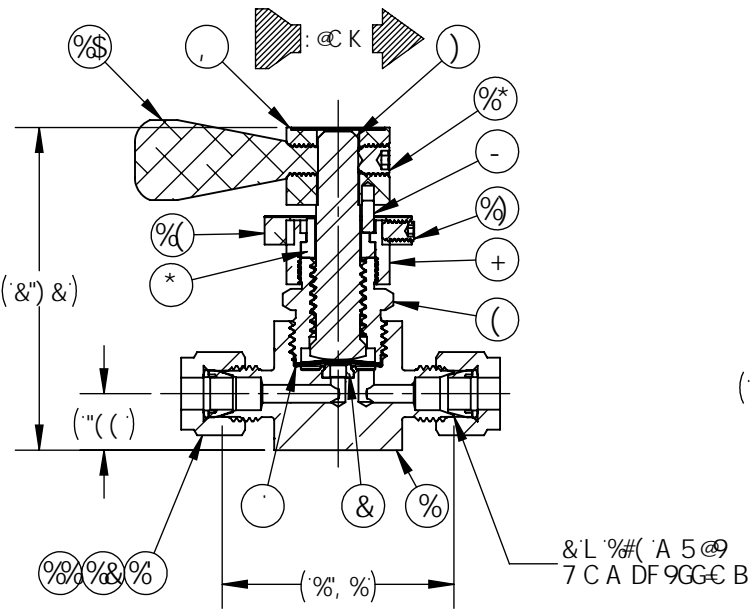
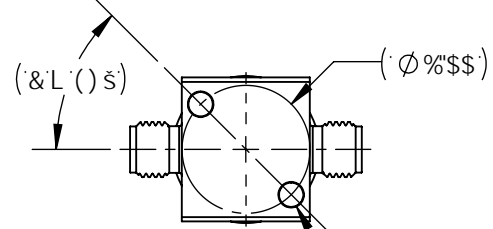
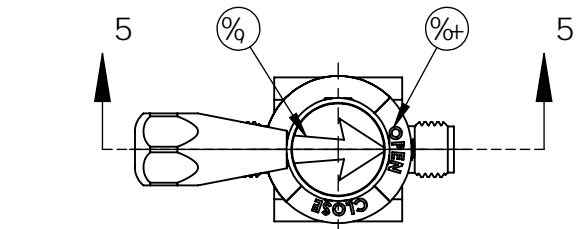
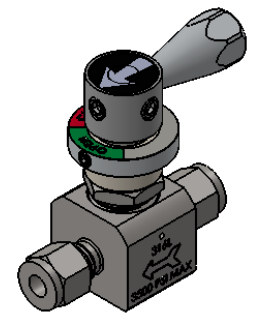

**G5@9G'8F 5K -B;**  
**I B7CBHFC @@8**  
**: CF**  
**F9: 9F9B79**  
**CB@M**

G97 HC B '5!5

UOX	OWUOPVAJOXQWQ	ÖOEVO
5	ÖÜVÖŠÖP ÖÖÜÖÜÖÜÖÜ ÖÖÖÜÜÖPÖÜÖÜÖÜ	€-H# EDEFI

OOOUOQVQWPK  
 XÖSXÖÁFÖ VÄÜŠÖÖÖÜŠFÖ ÖÜT ÜÁÁFÖ Á  
 ÖÜT ÜÁÜÜ  
 UÖÜVÖPWT ÖÖÜK  
**J @!E G@(( GG!77**

**5G: @C'DFC8I 7HG**  
**: UfzYXZB>\$+\$\$**  
 ÖÜÜÜK { a[ t&a Å } ÄE#I EDEFI

THIS DOCUMENT CONTAINS INFORMATION THAT IS THE PROPRIETARY AND CONFIDENTIAL PROPERTY OF GASFLU PRODUCTS INC. AND MAY BE USED ONLY FOR AUTHORIZED PURPOSES. THIS DOCUMENT MAY NOT BE REPRODUCED WITHOUT GASFLU PRODUCTS INC. PRIOR WRITTEN CONSENT.

UOZOA CE	UOCOSOA PVU	TÖEÖK G99'6'C'A"
UPOÖVÖPWT ÖÖÜK FAJÖAF	ÖÜÖÜP ÖÖÜK ÖÖÜK } I Å } ÄE#I EDEFI	